

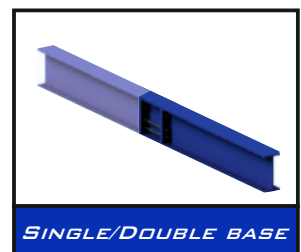

 **parsteel**

CANTILEVER SYSTEMS

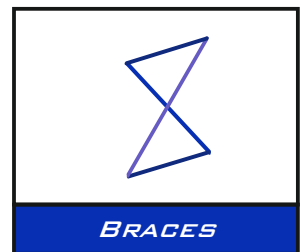
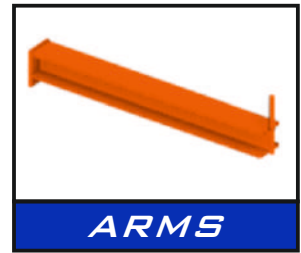
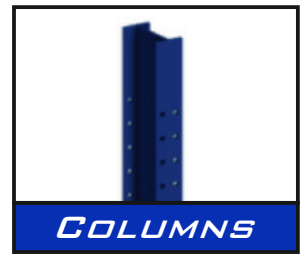
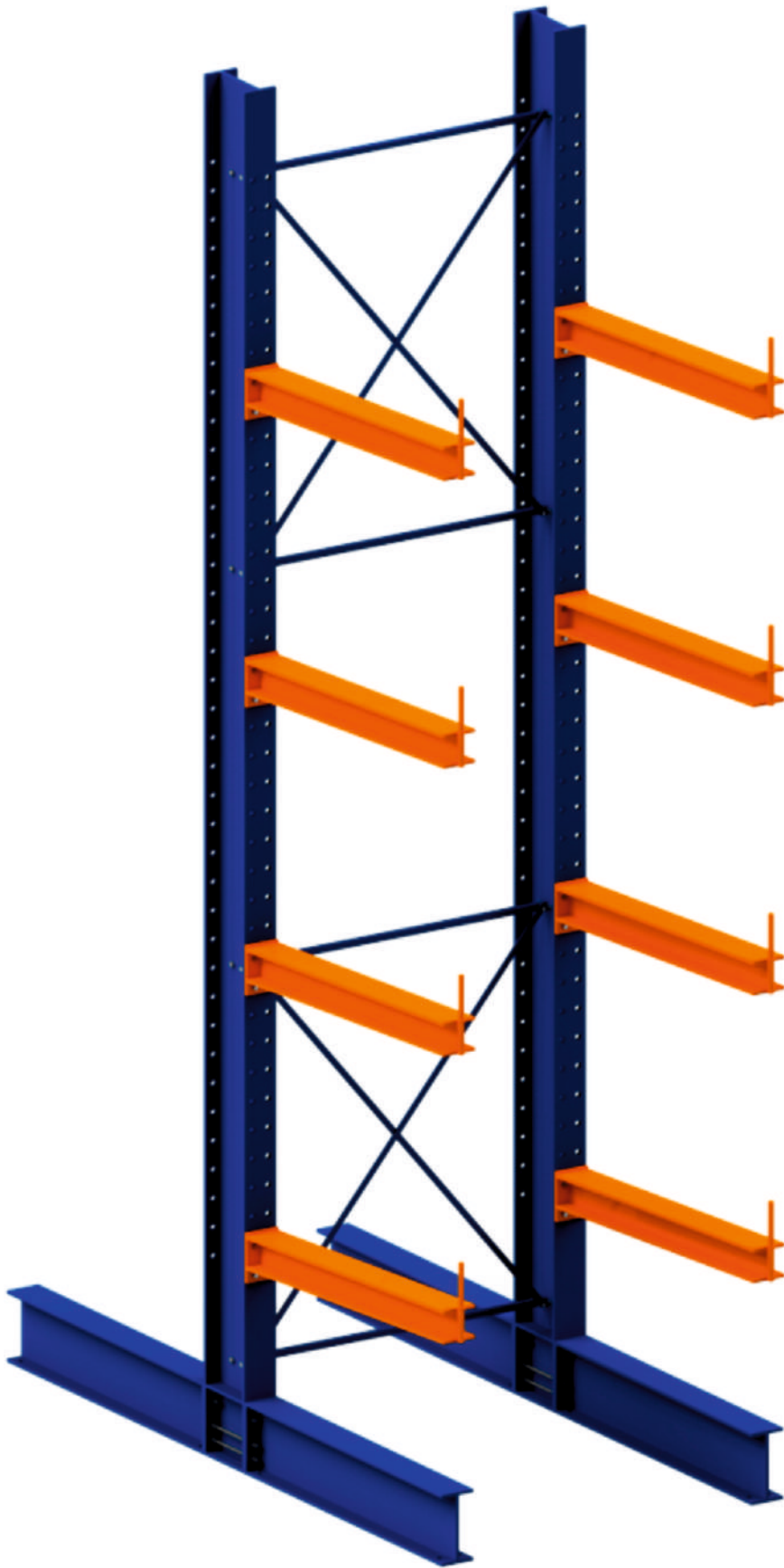

PARTS AND PIECES

Our cantilever racking is ideal for storing heavy, long-profile items such as lumber, pipes, steel bars, fabrics and other bulky materials. Its robust design provides the strength and capacity needed for heavy-duty applications, while the open layout offers easy access and organization for items with considerable length.

COLUMNS					
#	Height	Profile	Capacity (Lbs/Side)	Color	Weight (Lbs)
1	12'	5"X10"	11,70	Blue	209,00
2	16'	5"X10"	11,66	Blue	279,40
3	20'	5"X10"	11,44	Blue	349,80

ARMS					
#	Length	Profile	Capacity (Lbs/Side)	Color	Weight (Lbs)
1	36'	4.75"	3,960	Blue	29.04
2	48'	4.75"	3,960	Blue	41.70
3	60'	4.75"	3,300	Blue	55,99

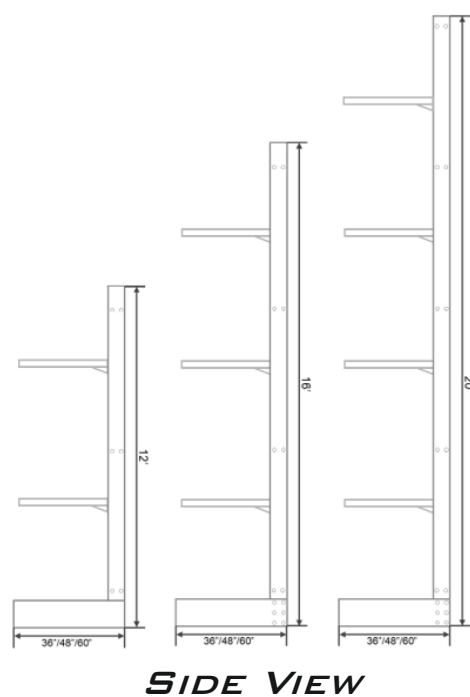
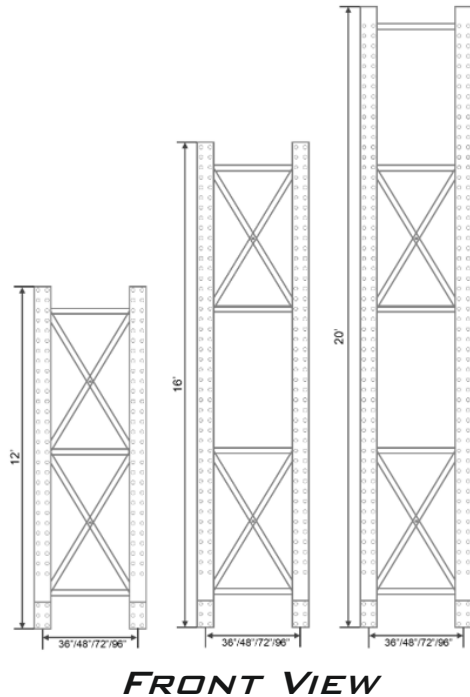
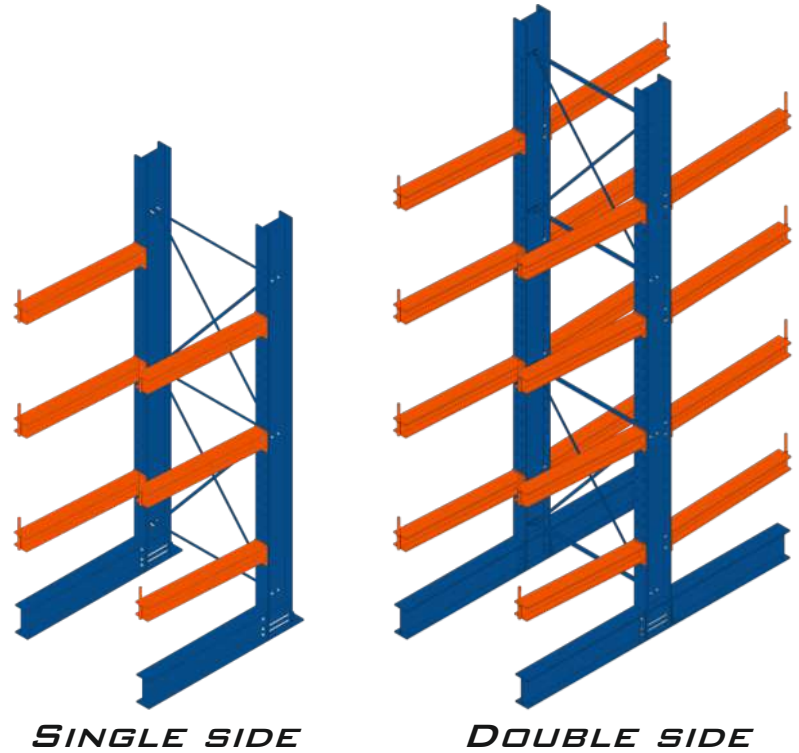
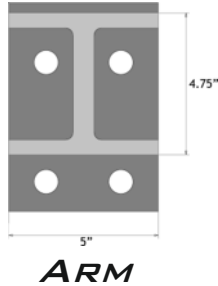
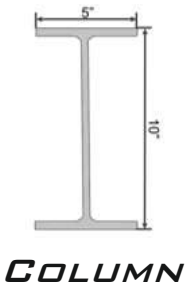

- Parsteel's Cantilever Racking has been designed for handling larger volume items such as lumber, pipes, and other bulky materials, while ensuring maximum efficiency and cost-effectiveness.
- Each STARTER UNIT includes two columns and brace sets according to its height.

- Each base requires four standard anchor bolts to secure it to the floor.
- Arms can be vertically adjusted every 4 inches for customizable storage heights.
- Each ADD-ON UNIT includes one column and brace sets according to its height.

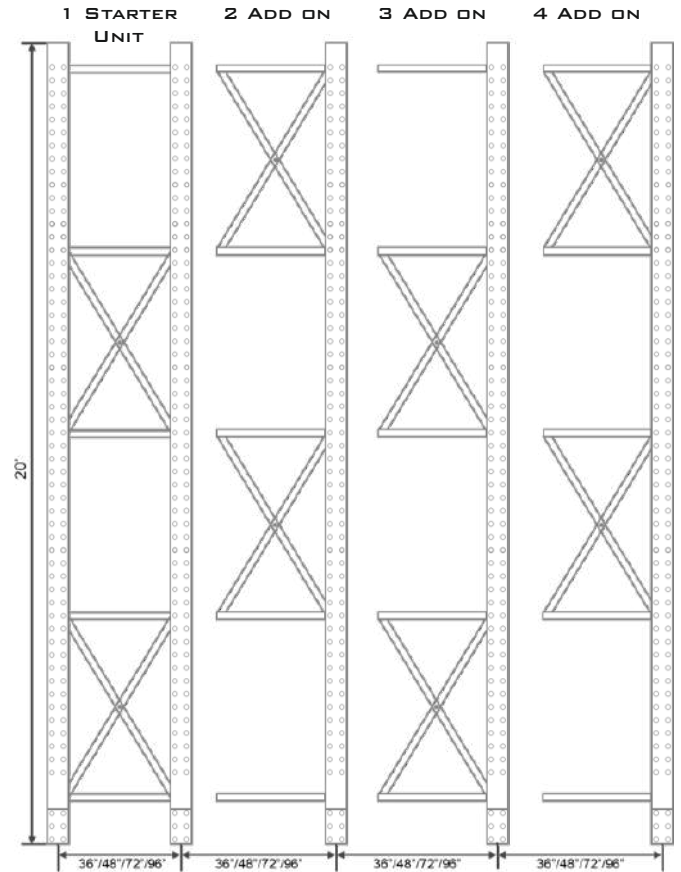
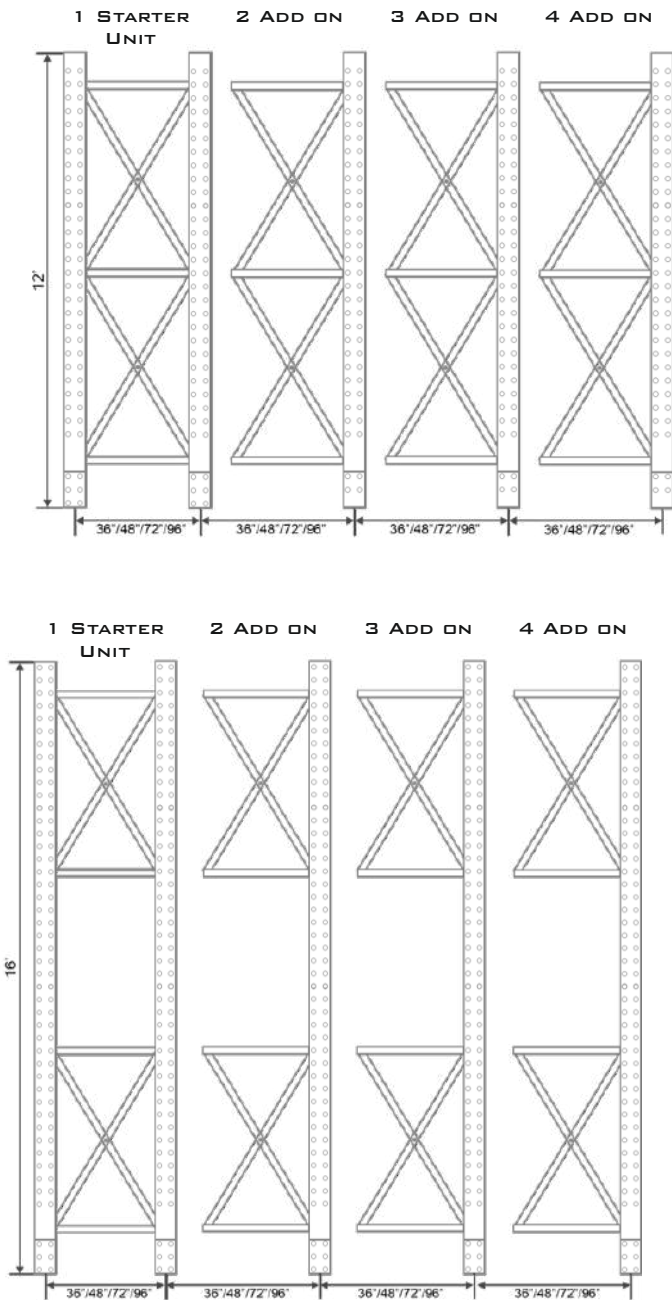

SINGLE SIDE STARTER UNIT

#	CODE	HEIGHT	DEPTH	WIDTH	BASE	CAPACITY PER SIDE	WEIGHT
1	CRS-SU144X48X48-S	12'	48	48	SINGLE	11,704 LBS	646 LBS
2	CRS-SU192X48X48-S	16'	48	48	SINGLE	11,660 LBS	798 LBS
3	CRS-SU240X48X48-S	20'	48	48	SINGLE	11,440 LBS	949 LBS
4	CRS-SU144X48X60-S	12'	48	60	SINGLE	11,704 LBS	656 LBS
5	CRS-SU192X48X60-S	16'	48	60	SINGLE	11,660 LBS	810 LBS
6	CRS-SU240X48X60-S	20'	48	60	SINGLE	11,440 LBS	964 LBS
7	CRS-SU144X60X48-S	12'	60	48	SINGLE	9,944 LBS	673 LBS
8	CRS-SU192X60X48-S	16'	60	48	SINGLE	9,900 LBS	825 LBS
9	CRS-SU240X60X48-S	20'	60	48	SINGLE	9,680 LBS	976 LBS
10	CRS-SU144X60X60-S	12'	60	60	SINGLE	9,944 LBS	683 LBS
11	CRS-SU192X60X60-S	16'	60	60	SINGLE	9,900 LBS	837 LBS
12	CRS-SU240X60X60-S	20'	60	60	SINGLE	9,680 LBS	991 LBS

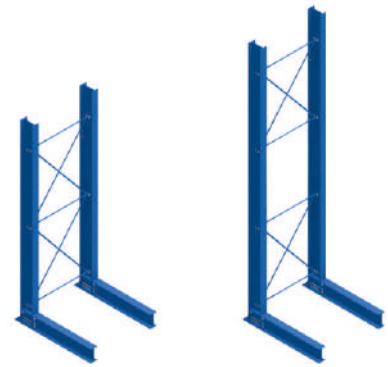

SINGLE SIDE ADD-ON UNIT

#	CODE	HEIGHT	DEPTH	WIDTH	BASE	CAPACITY PER SIDE	WEIGHT
1	CRS-AO144X48X48-S	12'	48	48	SINGLE	11,704 LBS	353 LBS
2	CRS-AO192X48X48-S	16'	48	48	SINGLE	11,660 LBS	434 LBS
3	CRS-AO240X48X48-S	20'	48	48	SINGLE	11,440 LBS	515 LBS
4	CRS-AO144X48X60-S	12'	48	60	SINGLE	11,704 LBS	363 LBS
5	CRS-AO192X48X60-S	16'	48	60	SINGLE	11,660 LBS	447 LBS
6	CRS-AO240X48X60-S	20'	48	60	SINGLE	11,440 LBS	530 LBS
7	CRS-AO144X60X48-S	12'	60	48	SINGLE	9,944 LBS	367 LBS
8	CRS-AO192X60X48-S	16'	60	48	SINGLE	9,900 LBS	448 LBS
9	CRS-AO240X60X48-S	20'	60	48	SINGLE	9,680 LBS	529 LBS
10	CRS-AO144X60X60-S	12'	60	60	SINGLE	9,944 LBS	377 LBS
11	CRS-AO192X60X60-S	16'	60	60	SINGLE	9,900 LBS	461 LBS
12	CRS-AO240X60X60-S	20'	60	60	SINGLE	9,680 LBS	538 LBS

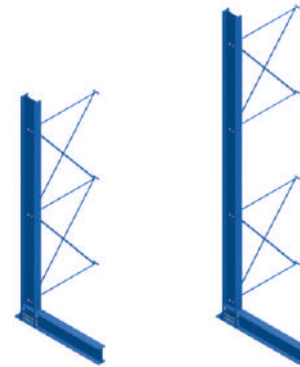

DOUBLE SIDE STARTER UNIT

#	CODE	HEIGHT	DEPTH	WIDTH	BASE	CAPACITY PER SIDE	WEIGHT
1	CRS-SU144X48X48-D	12'	48	48	DOUBLE	11,704 LBS	785 LBS
2	CRS-SU192X48X48-D	16'	48	48	DOUBLE	11,660 LBS	936 LBS
3	CRS-SU240X48X48-D	20'	48	48	DOUBLE	11,440 LBS	1,088 LBS
4	CRS-SU144X48X60-D	12'	48	60	DOUBLE	11,704 LBS	795 LBS
5	CRS-SU192X48X60-D	16'	48	60	DOUBLE	11,660 LBS	949 LBS
6	CRS-SU240X48X60-D	20'	48	60	DOUBLE	11,440 LBS	1,103 LBS
7	CRS-SU144X60X48-D	12'	60	48	DOUBLE	9,944 LBS	839 LBS
8	CRS-SU192X60X48-D	16'	60	48	DOUBLE	9,900 LBS	991 LBS
9	CRS-SU240X60X48-D	20'	60	48	DOUBLE	9,680 LBS	1,142 LBS
10	CRS-SU144X60X60-D	12'	60	60	DOUBLE	9,944 LBS	849 LBS
11	CRS-SU192X60X60-D	16'	60	60	DOUBLE	9,900 LBS	1,003 LBS
12	CRS-SU240X60X60-D	20'	60	60	DOUBLE	9,680 LBS	1,146 LBS

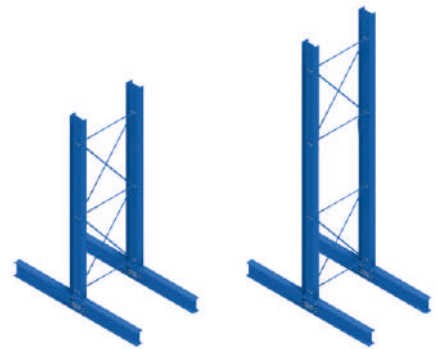

DOUBLE SIDE ADD-ON UNIT

#	CODE	HEIGHT	DEPTH	WIDTH	BASE	CAPACITY PER SIDE	WEIGHT
1	CRS-AO144X48X48-D	12'	48	48	DOUBLE	11,704 LBS	423 LBS
2	CRS-AO192X48X48-D	16'	48	48	DOUBLE	11,660 LBS	504 LBS
3	CRS-AO240X48X48-D	20'	48	48	DOUBLE	11,440 LBS	585 LBS
4	CRS-AO144X48X60-D	12'	48	60	DOUBLE	11,704 LBS	433 LBS
5	CRS-AO192X48X60-D	16'	48	60	DOUBLE	11,660 LBS	516 LBS
6	CRS-AO240X48X60-D	20'	48	60	DOUBLE	11,440 LBS	599 LBS
7	CRS-AO144X60X48-D	12'	60	48	DOUBLE	9,944 LBS	450 LBS
8	CRS-AO192X60X48-D	16'	60	48	DOUBLE	9,900 LBS	531 LBS
9	CRS-AO240X60X48-D	20'	60	48	DOUBLE	9,680 LBS	612 LBS
10	CRS-AO144X60X60-D	12'	60	60	DOUBLE	9,944 LBS	460 LBS
11	CRS-AO192X60X60-D	16'	60	60	DOUBLE	9,900 LBS	543 LBS
12	CRS-AO240X60X60-D	20'	60	60	DOUBLE	9,680 LBS	627 LBS

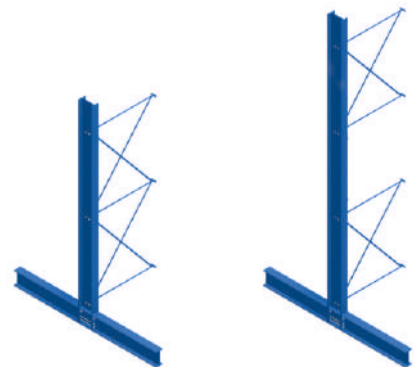

- Using the appropriate number of cantilever arms helps protect your products from deflection caused by sagging. Additionally, it prevents damage to the cantilever system by avoiding unnecessary pressure on the arms. In order to determine the number of arms needed, we perform the following test.

1) Place two wooden blocks (each 5 inches wide), such that when you place the load on top, there is a $1/4$ of the total load length overhanging on each side (measuring from the center of the wooden block to the edge of the load). Refer to the image below.

2) If you notice any sagging in the product, it will be necessary to add another wooden block, but instead of overhanging $1/4$ of the total length of the product, it should only overhang $1/6$.

3) If there is sagging in the product, you will need to add another wooden block. However, instead of overhanging $1/6$ of the total product length, it should only overhang $1/8$.

4) If the product still shows sagging after adding another wooden block, you should continue adding intermediate wooden blocks until no sagging is observed. Ensure the outer blocks overhang by $1/8$ of the total product length and keep the distance between the internal blocks consistent.

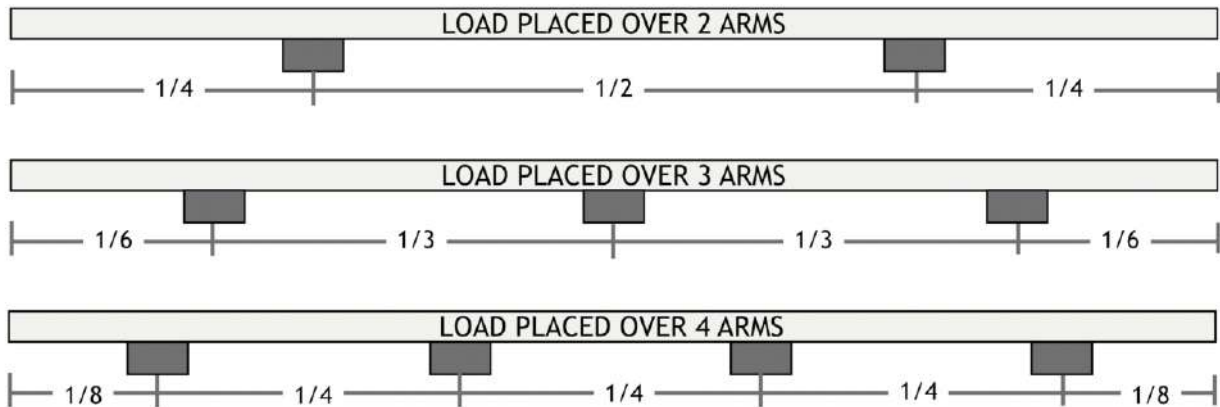

CALCULATING YOUR ARM LENGTH

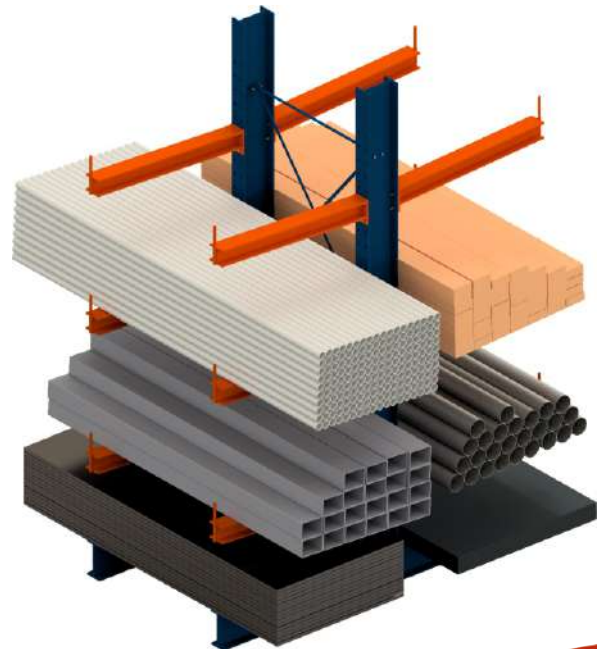
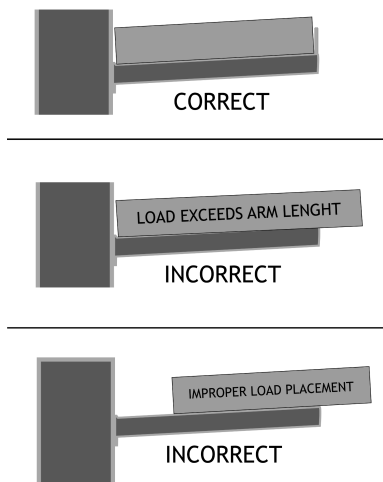

CALCULATING YOUR ARM HEIGHT

- The cantilevers total height is determined by the following equation:

$$BH+PH+(CH+AH+PH) \times (NL-1) = \text{Upright Height}$$

BH: Base Height AH: Arm Height
 PH: Product Height NL: Number of Levels
 CH: Clearance Height

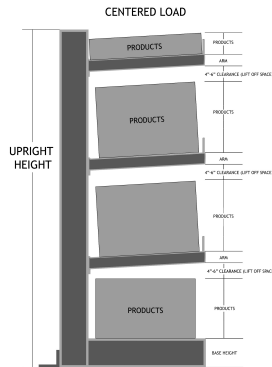

CALCULATING YOUR CANTILEVER CAPACITY

To calculate The capacity of each cantilever column, use the following formula:

$$\frac{\text{Number of arms} \times \text{Capacity of each arm}}{\text{Number of Columns}} = \text{Capacity per Columns}$$

- For example, a cantilever configuration of 12 arms, with a capacity of 3,260 lbs each, the total system capacity would be 39,040 lbs. If 3 columns were used the capacity of each column should be 13,040 lbs.

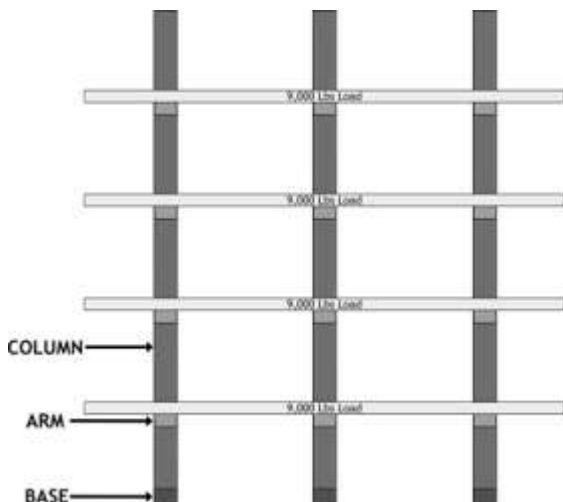

CALCULATING YOUR ARM CAPACITY

- By keeping your load centered and ensuring the load stays within the arms length, the capacity is calculated by dividing load weight by the number of supporting arms.

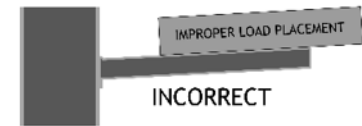
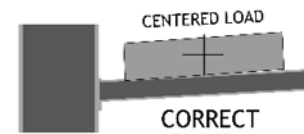
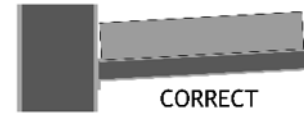



PALLET RACKS



PUSH-BACKS



CANTILEVERS



DRIVE-IN / THRU



PALLET JACK



RIVET SHELVINGS



STEEL SHELVINGS



MEZZANINES



PALLETS & CARTON FLOW



CONTACT US

 305-821-3000

 www.parsteel.com

 7527 W 20TH AVE Hialeah,
FL 33014, United States

 parsteel